

20.30.1023.00

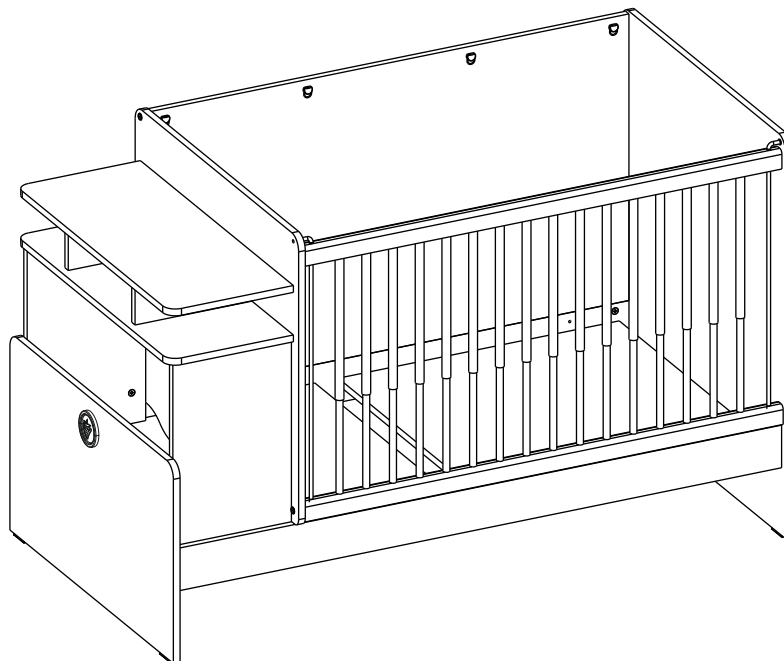

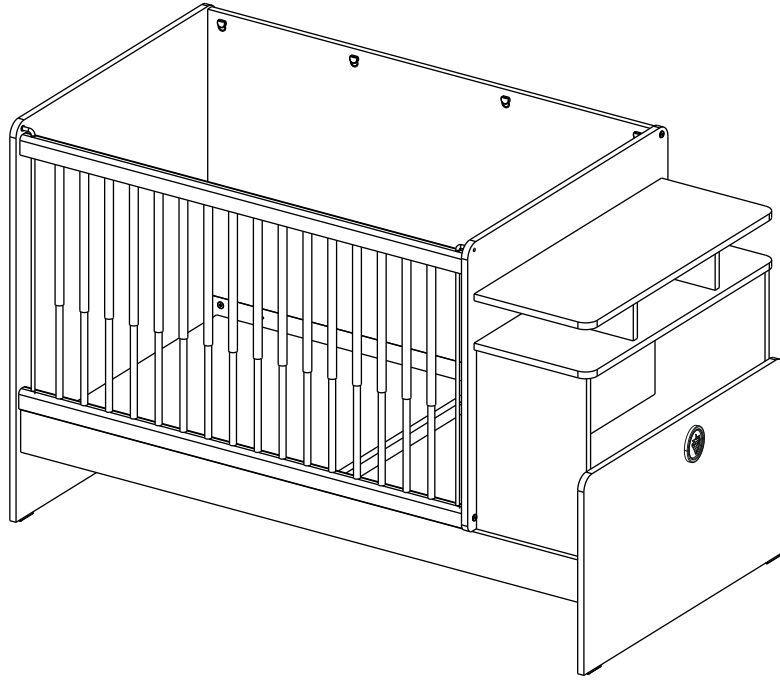

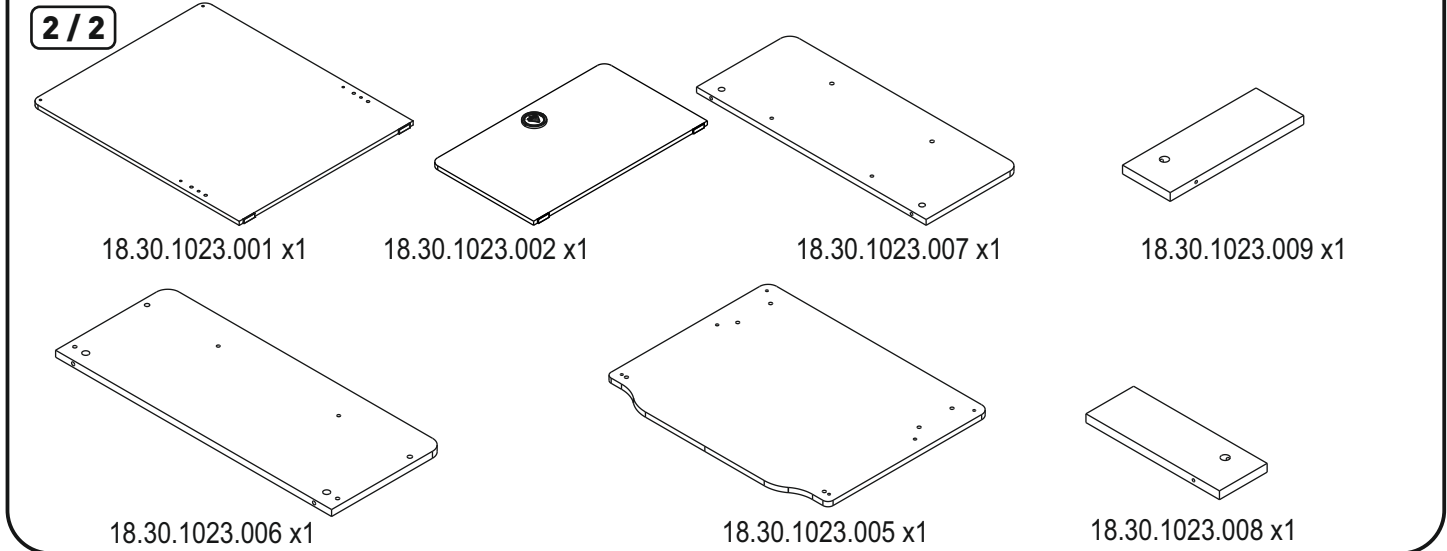
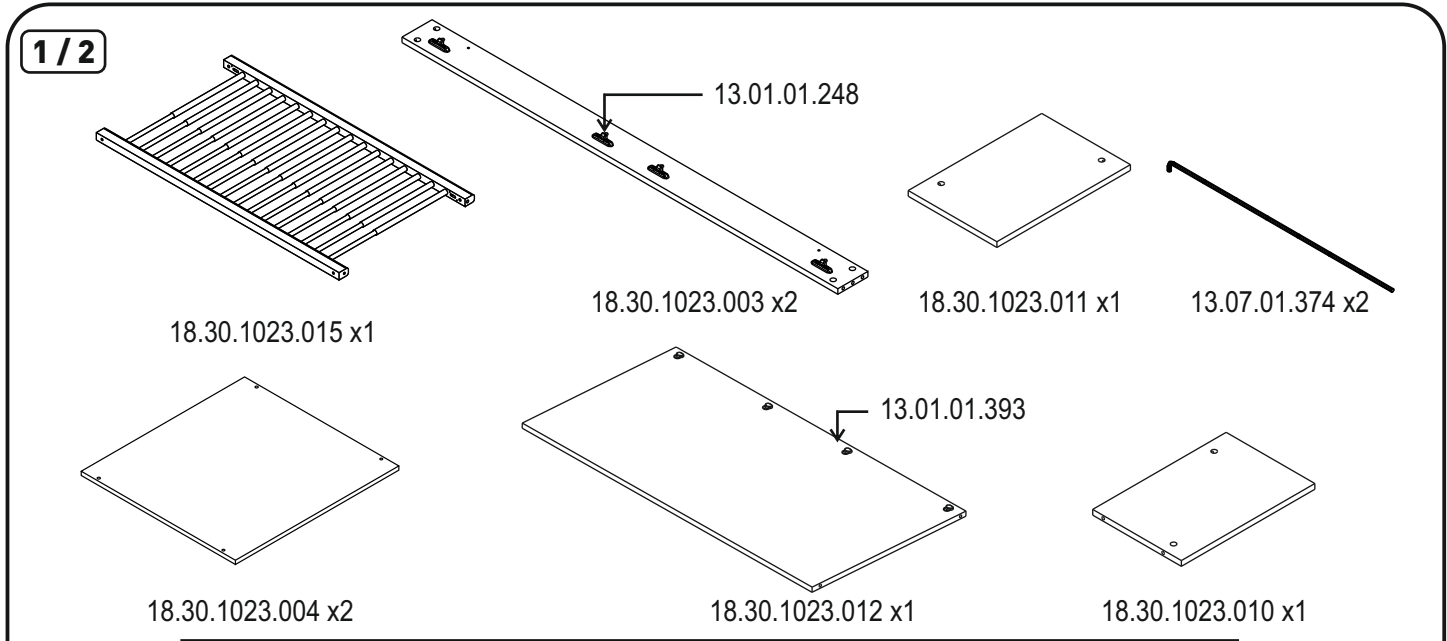
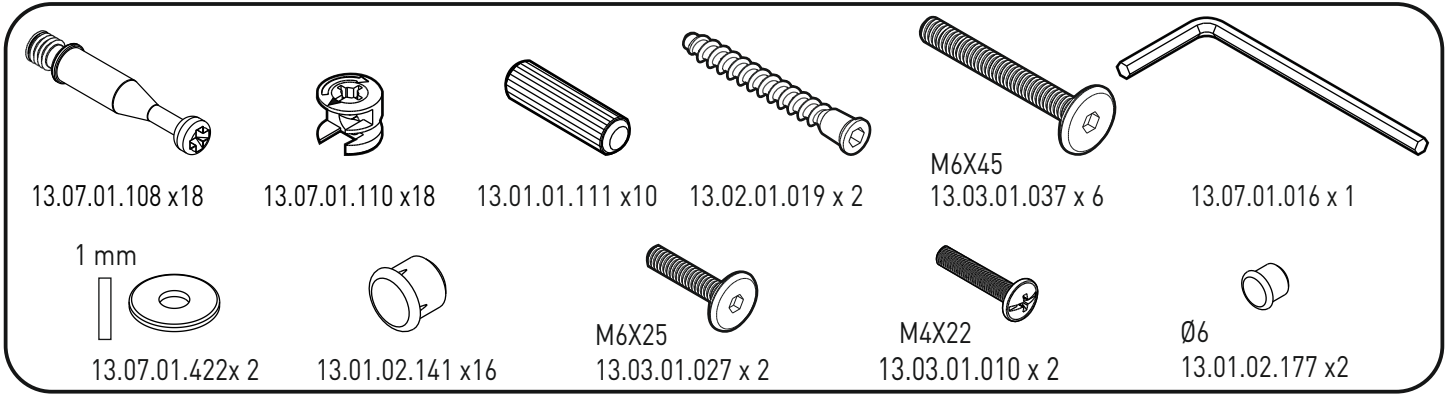
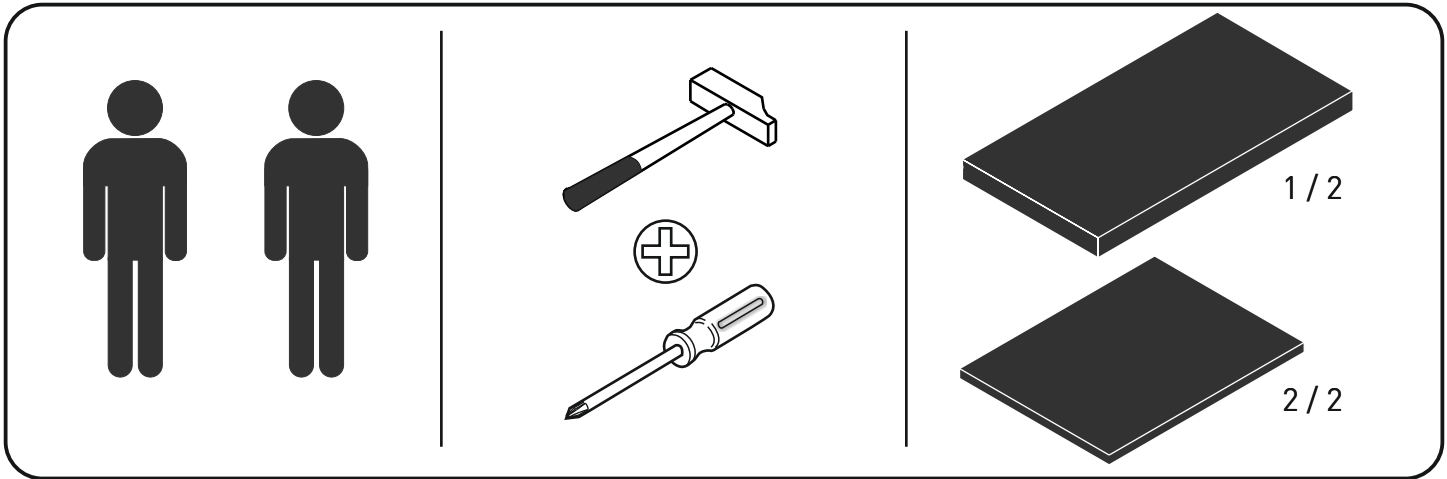
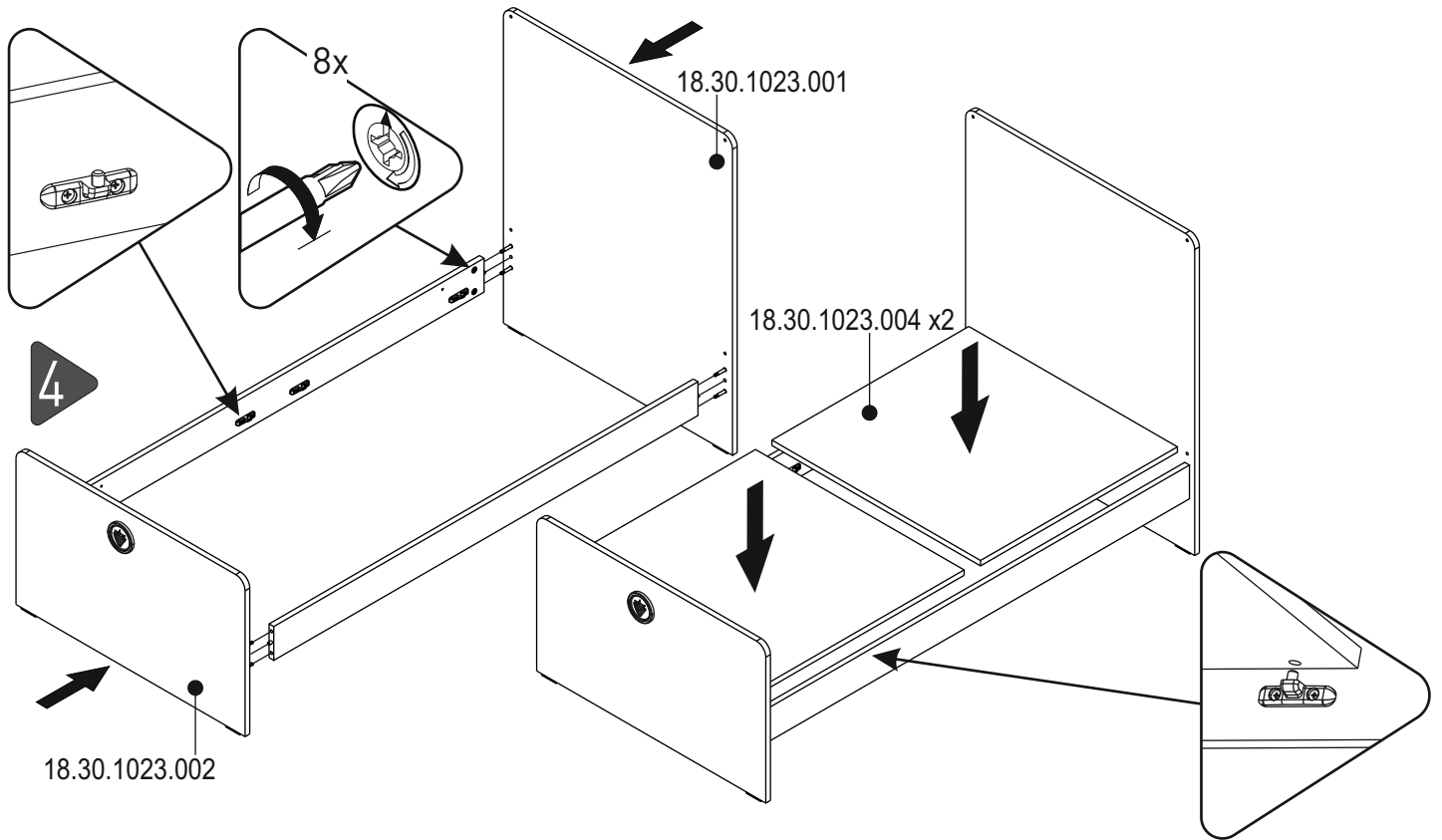
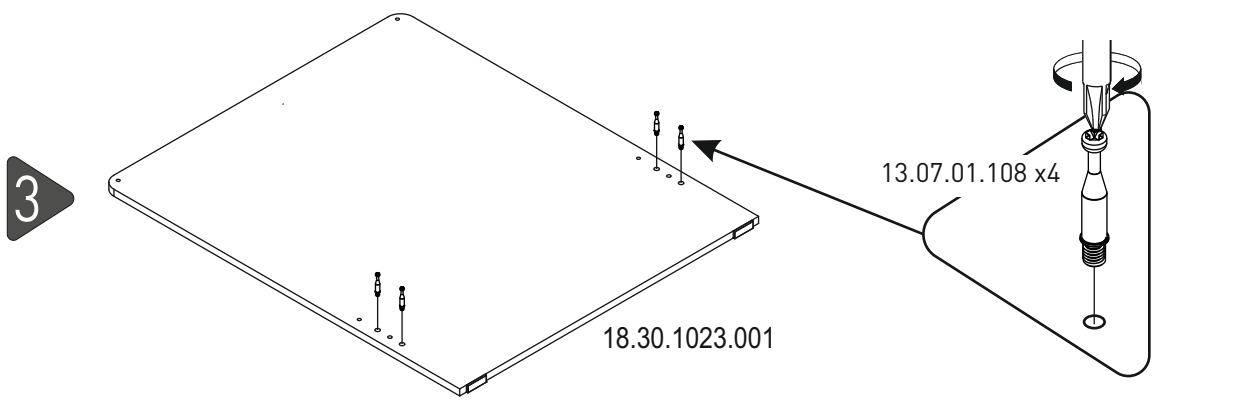
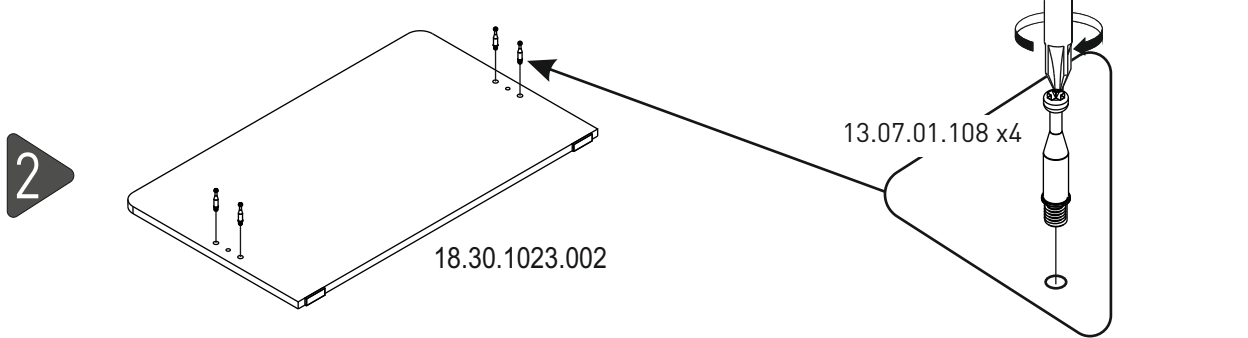
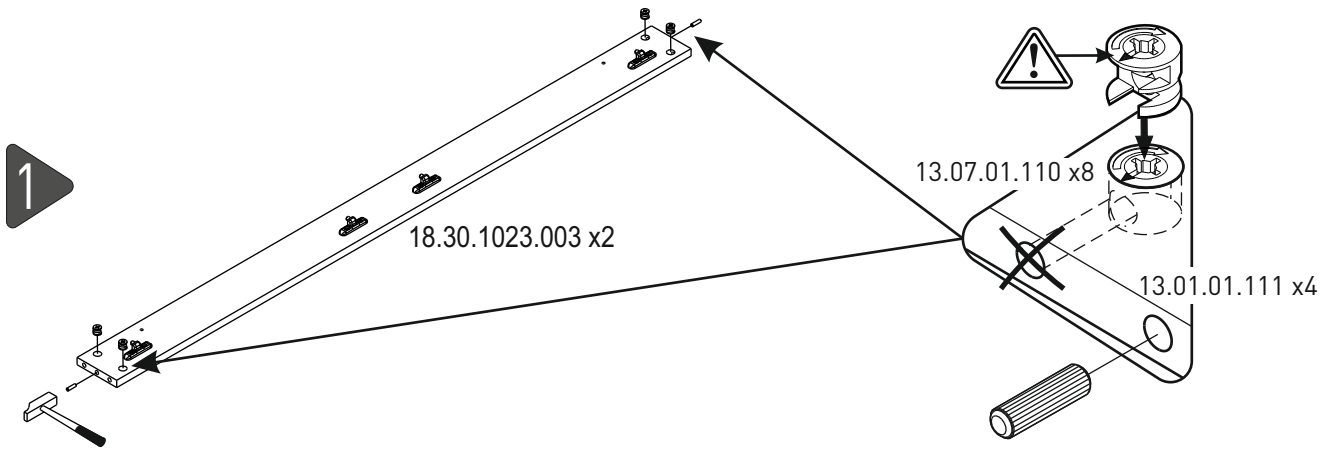

5

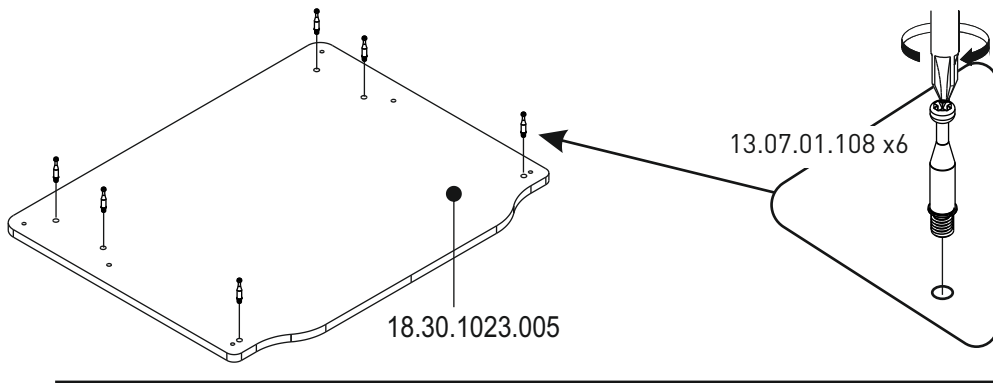

6

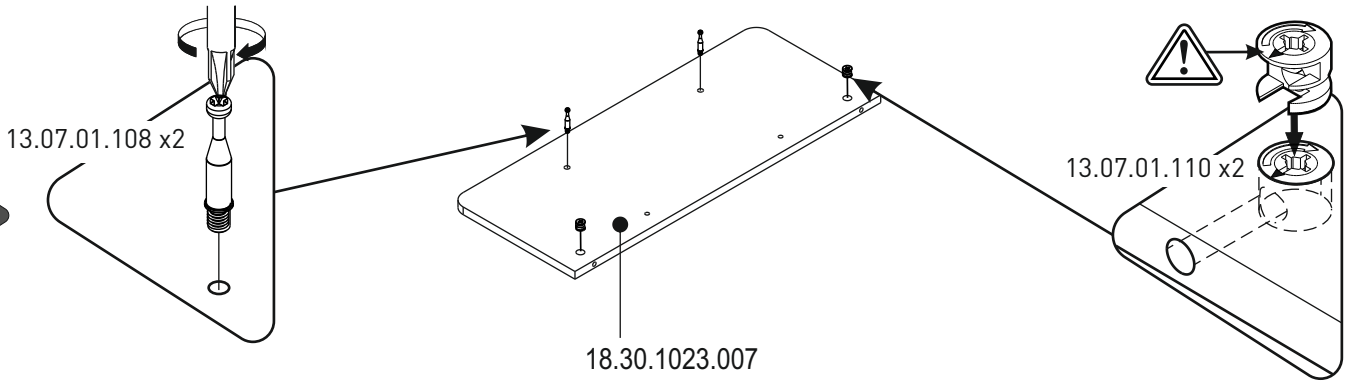

7

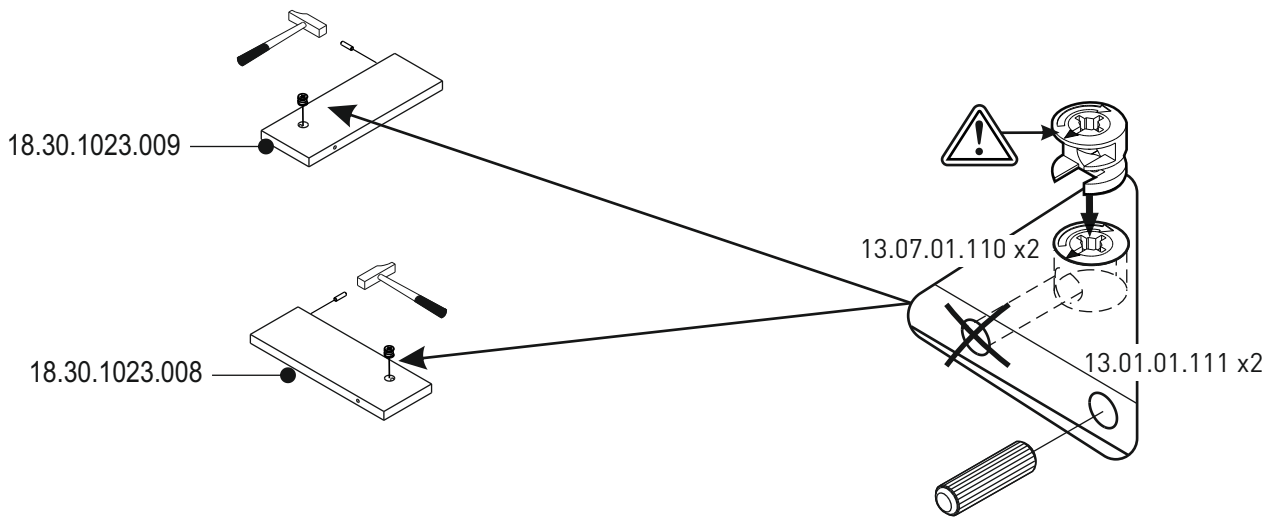

8

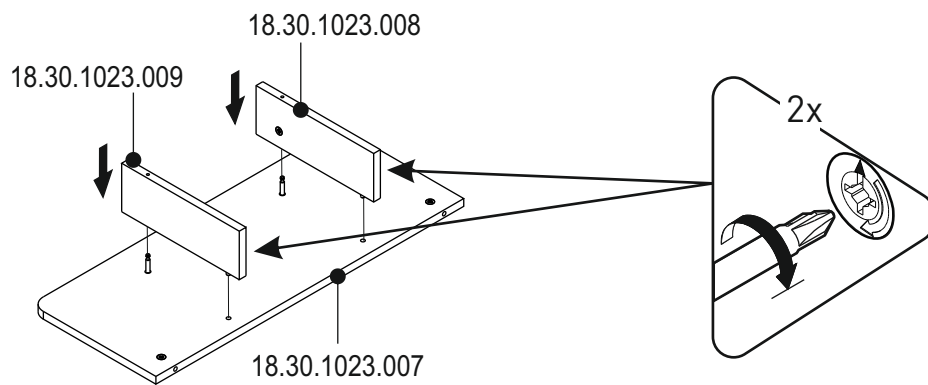

9

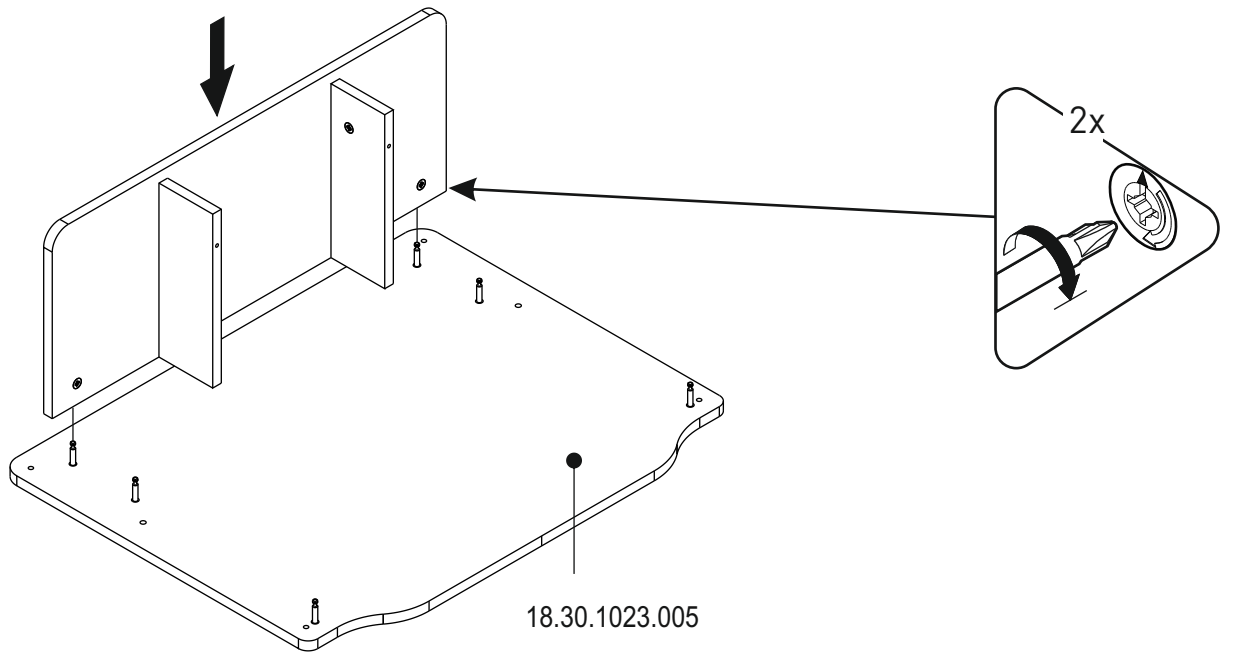

10

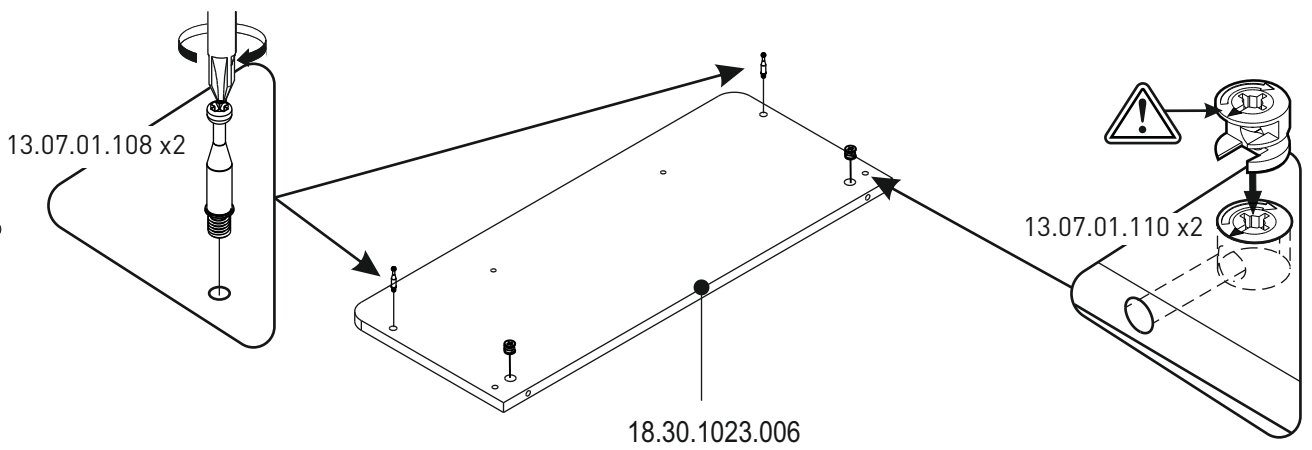

11

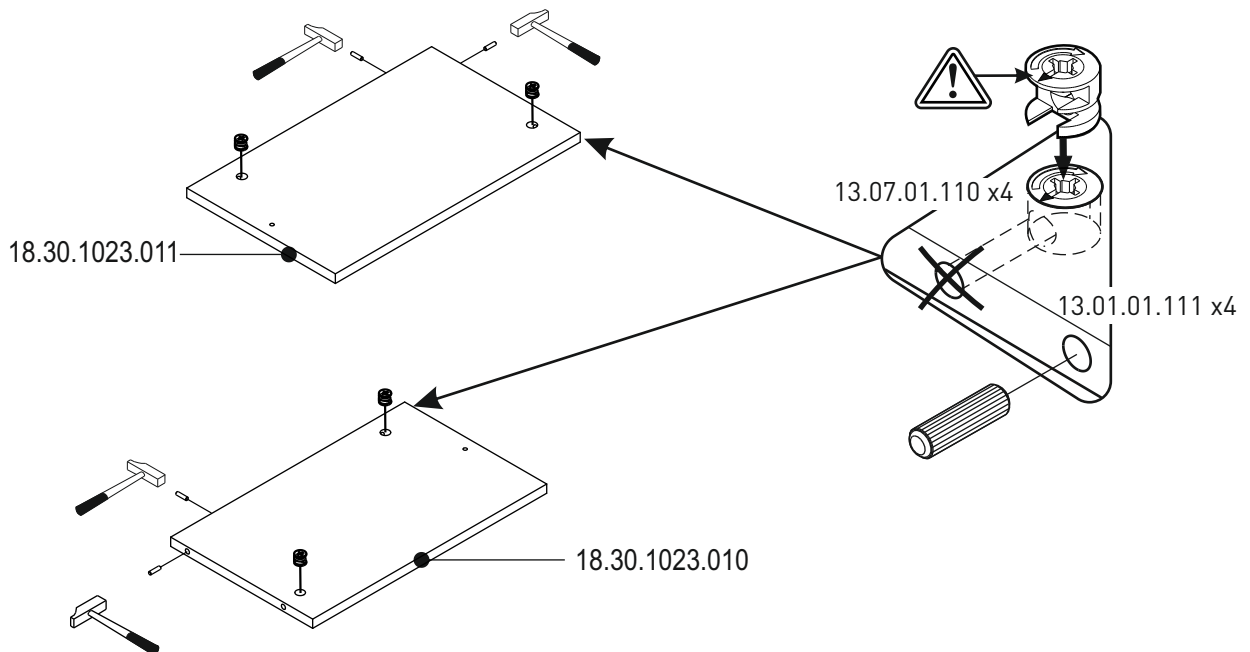

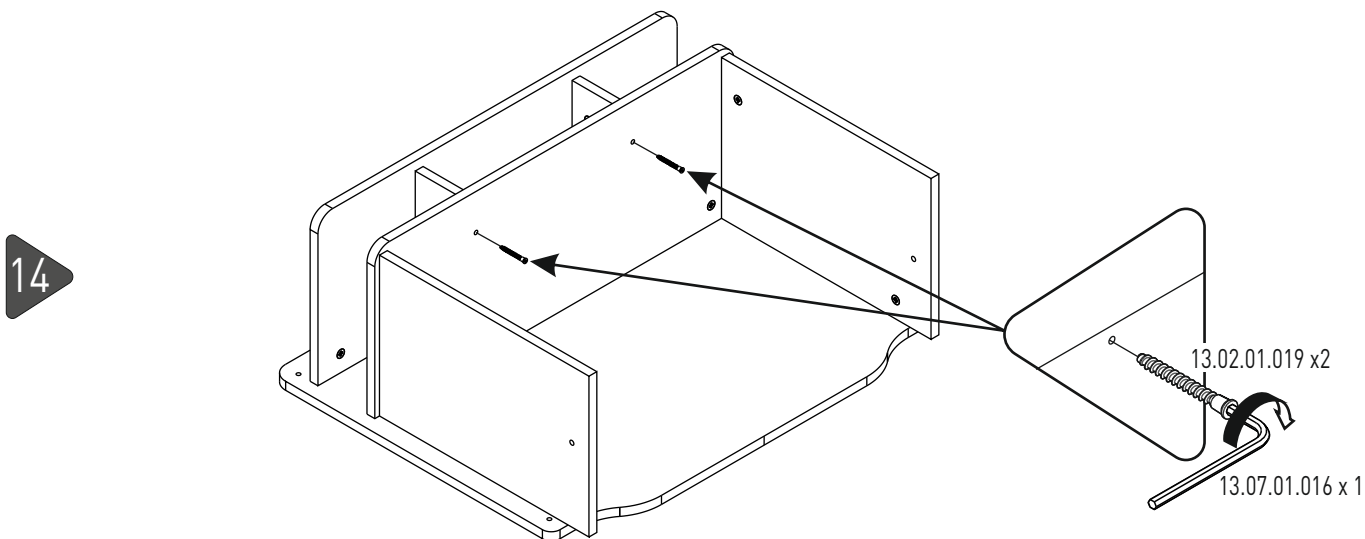
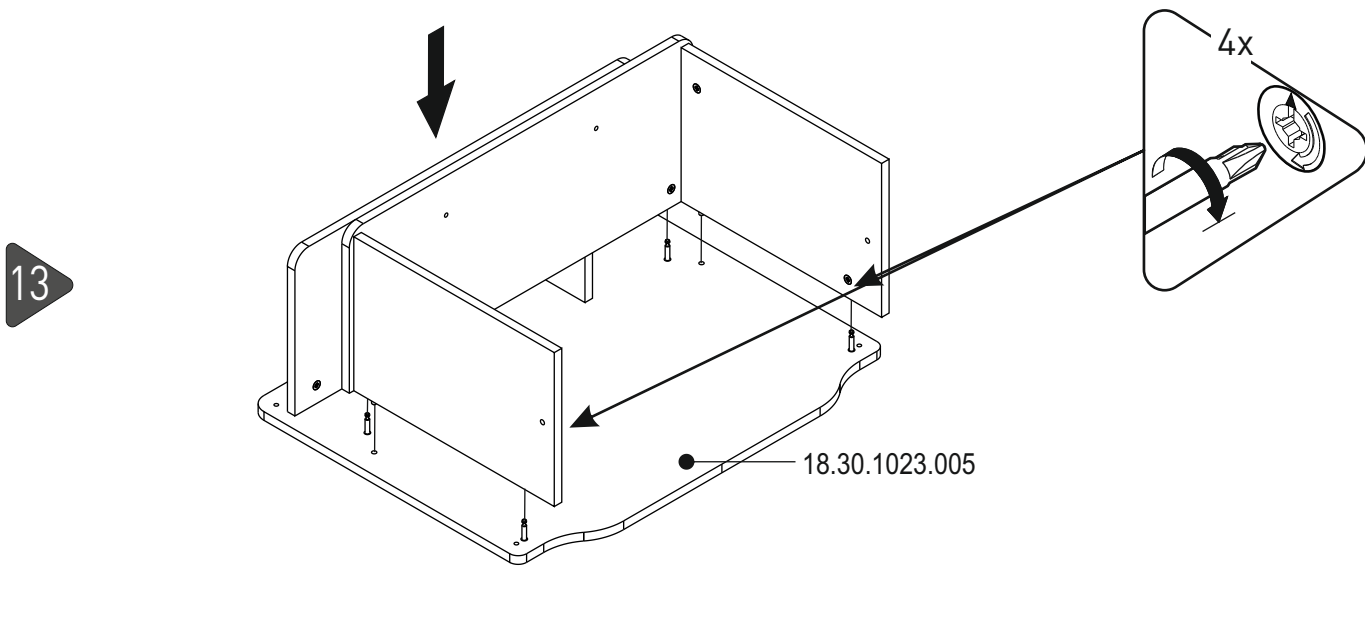
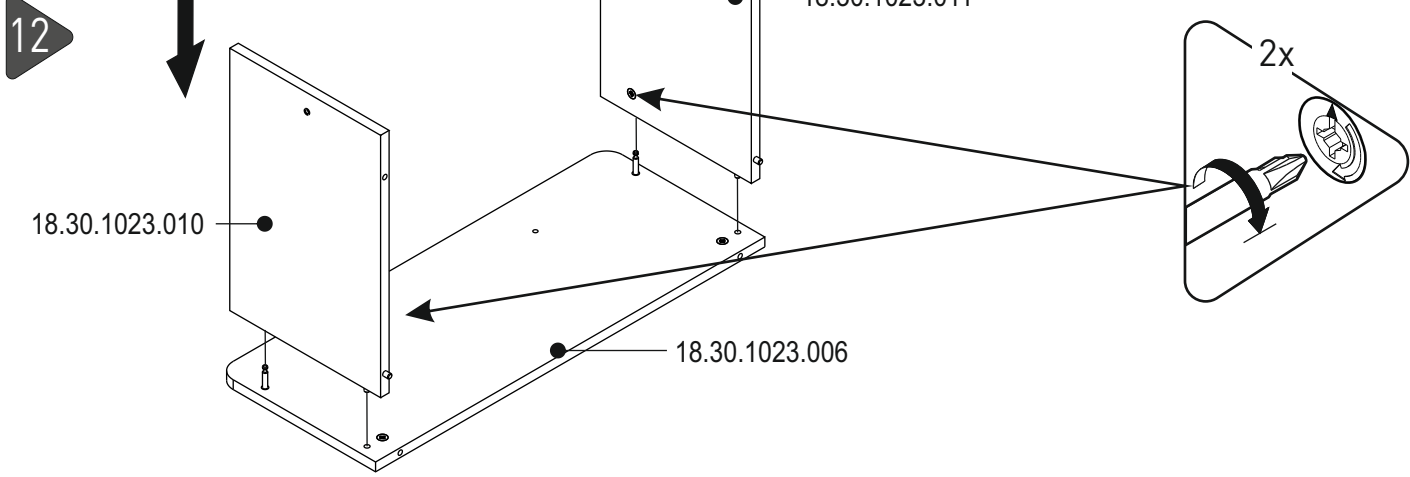

15a

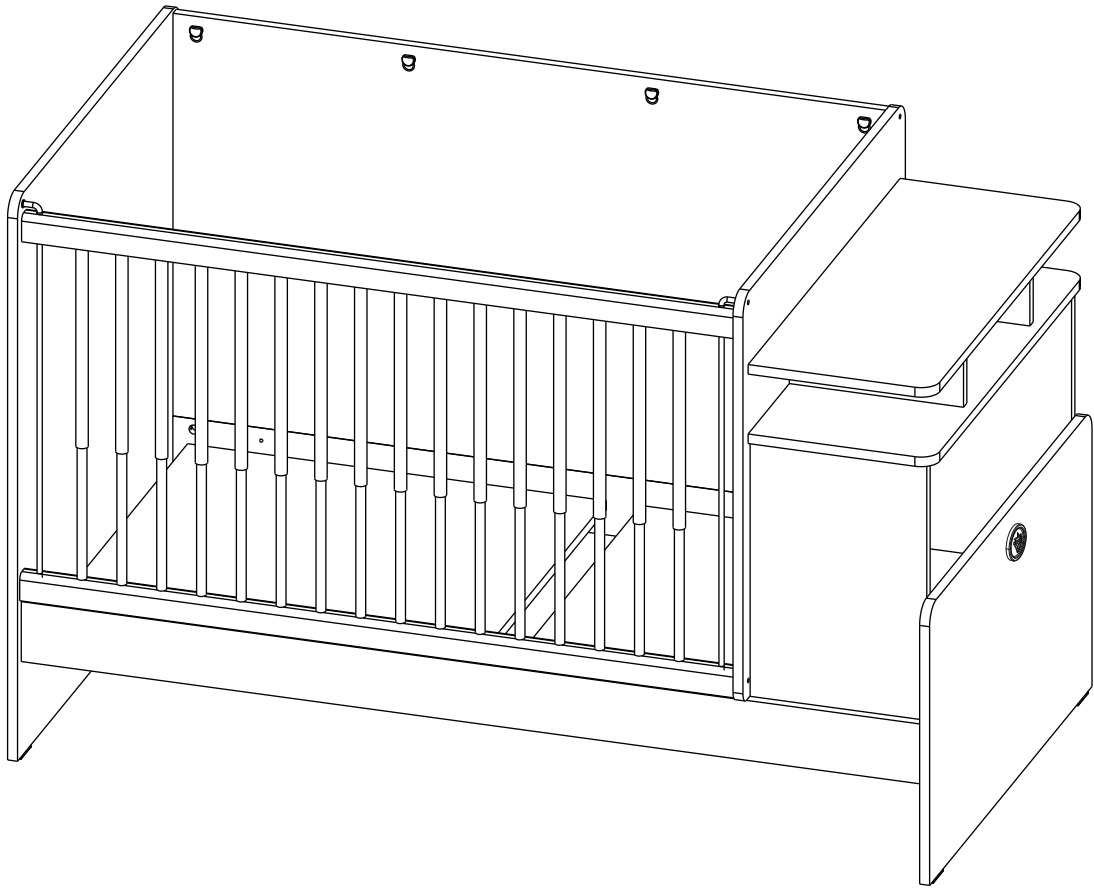

15b

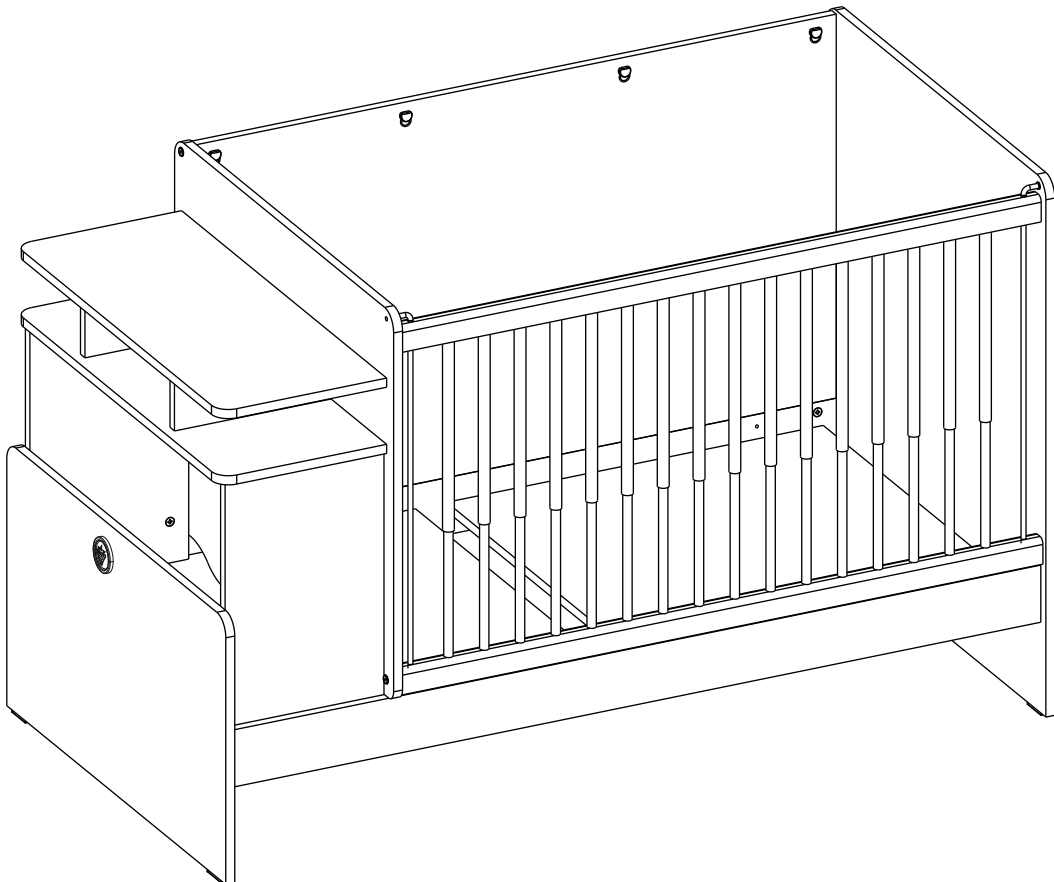

16a

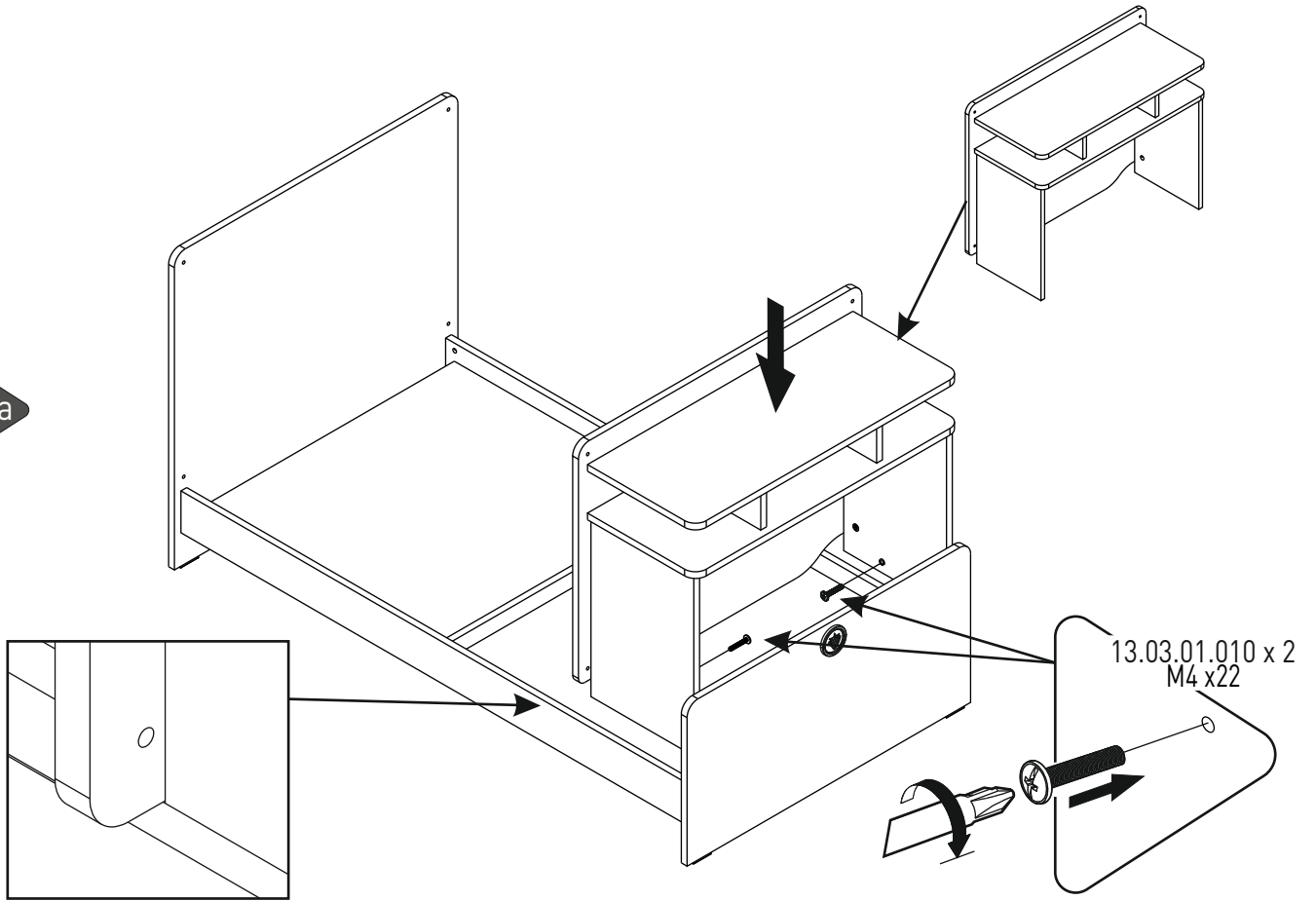

16b

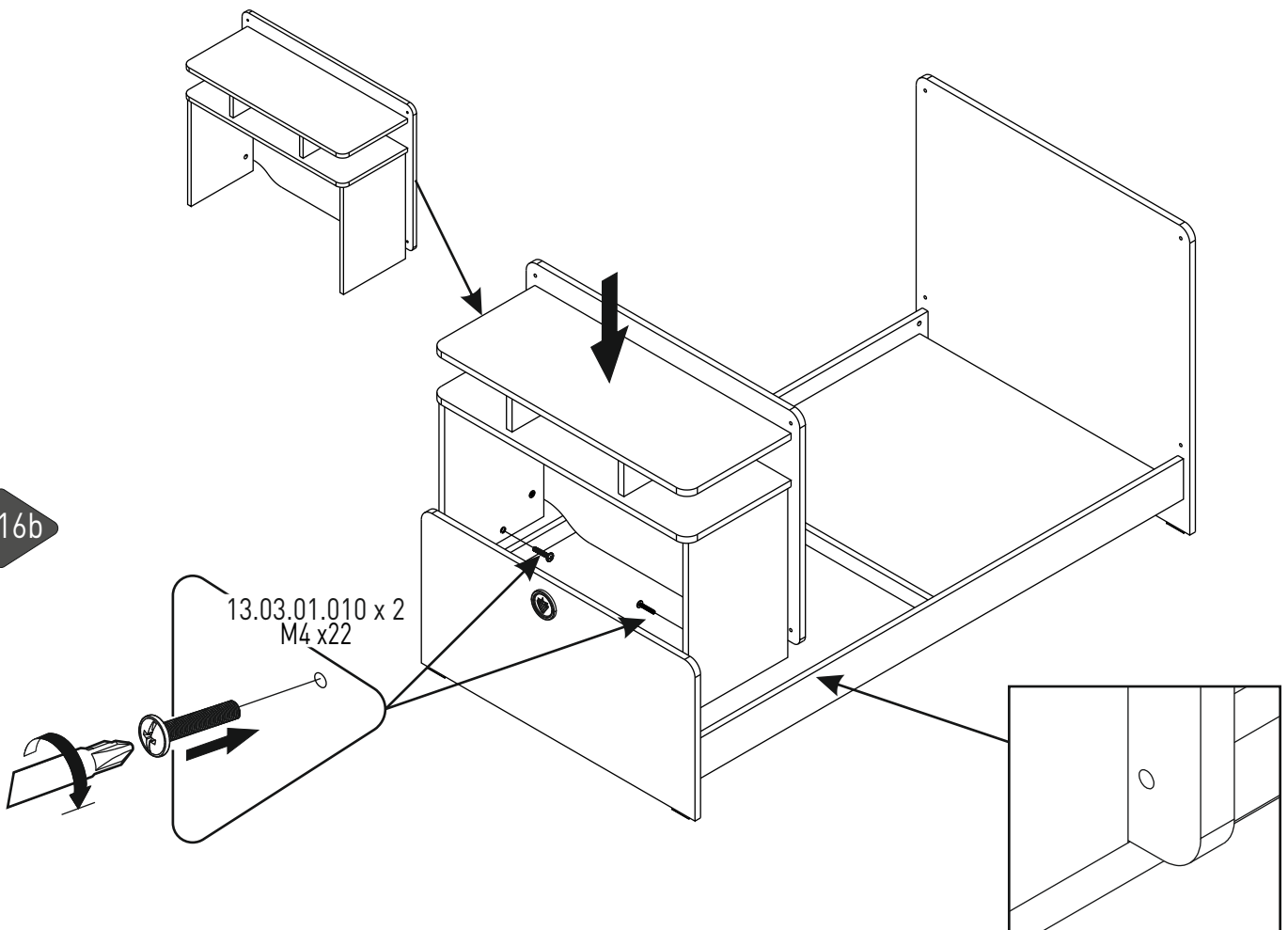

17

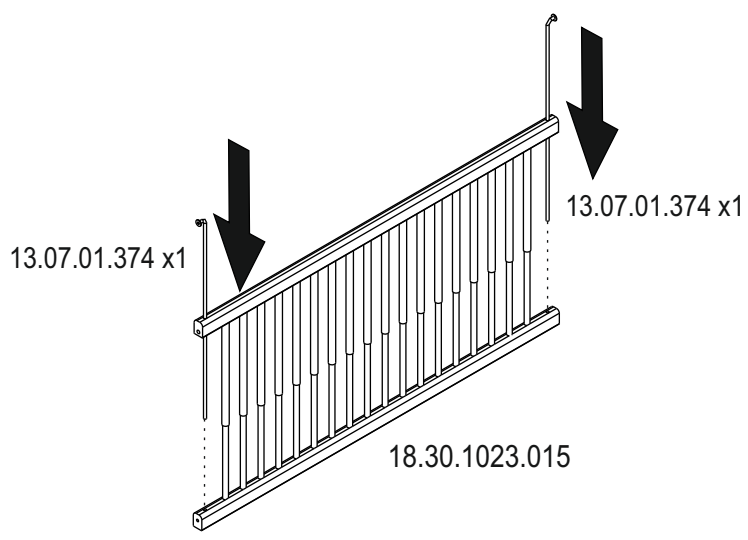

18a

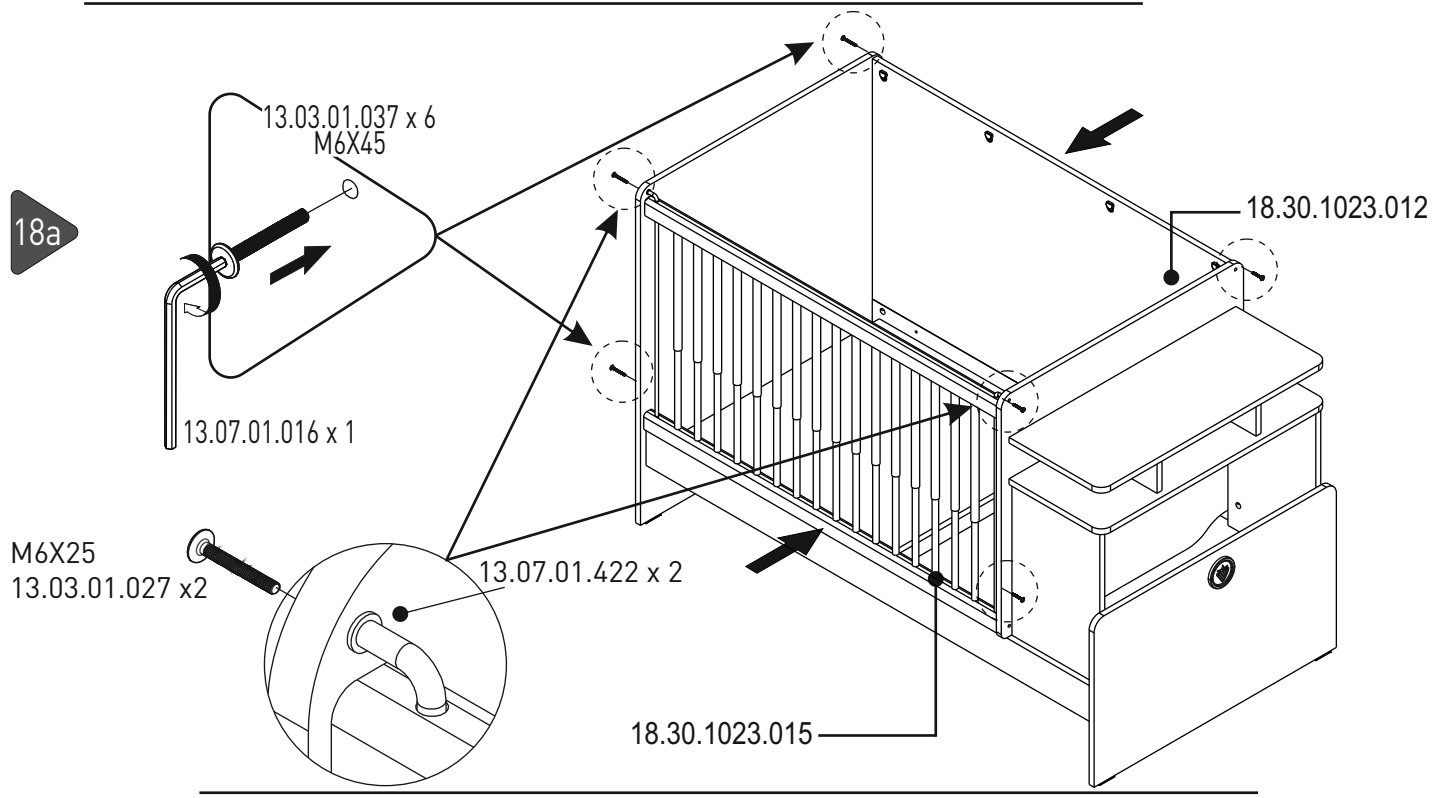

18b

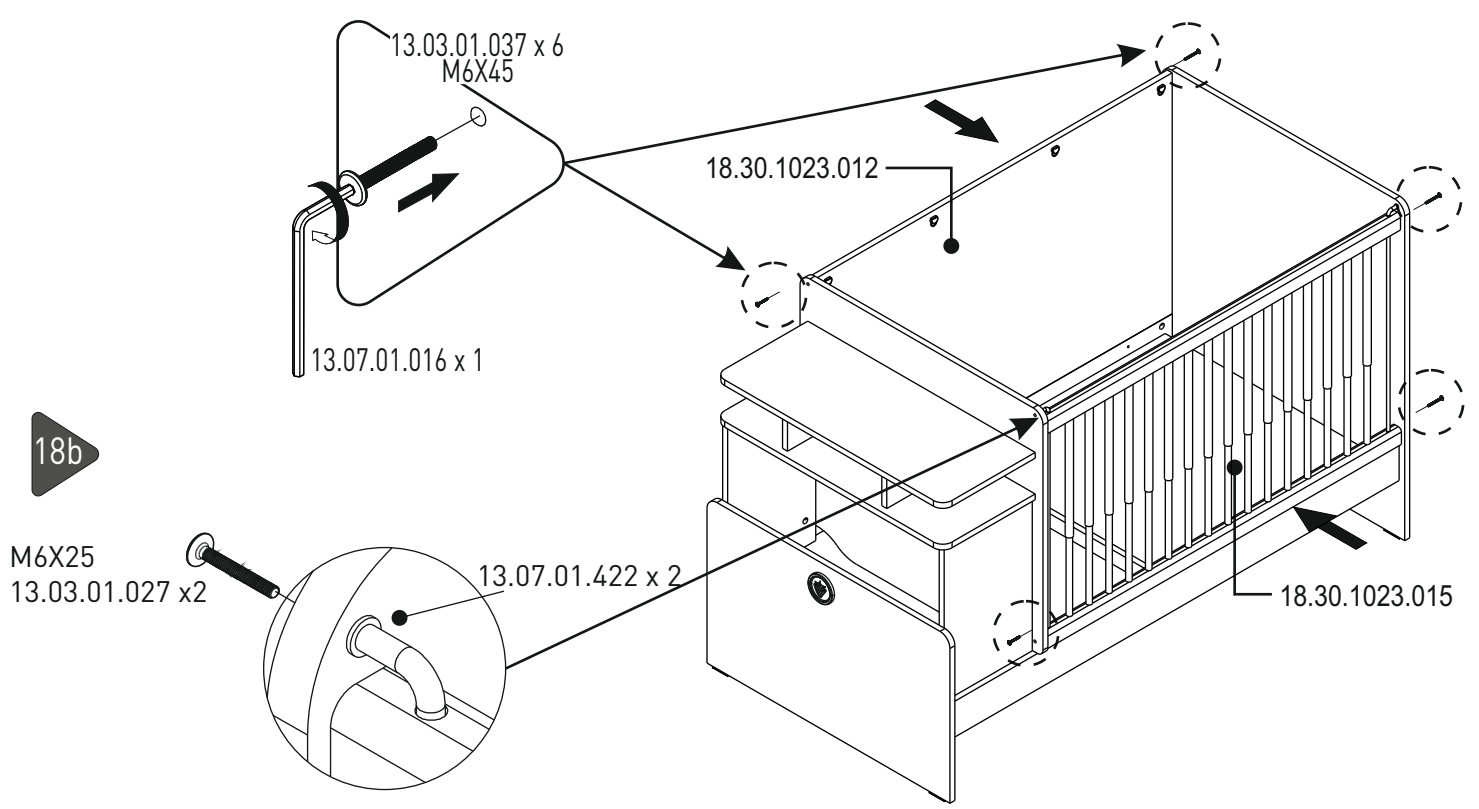

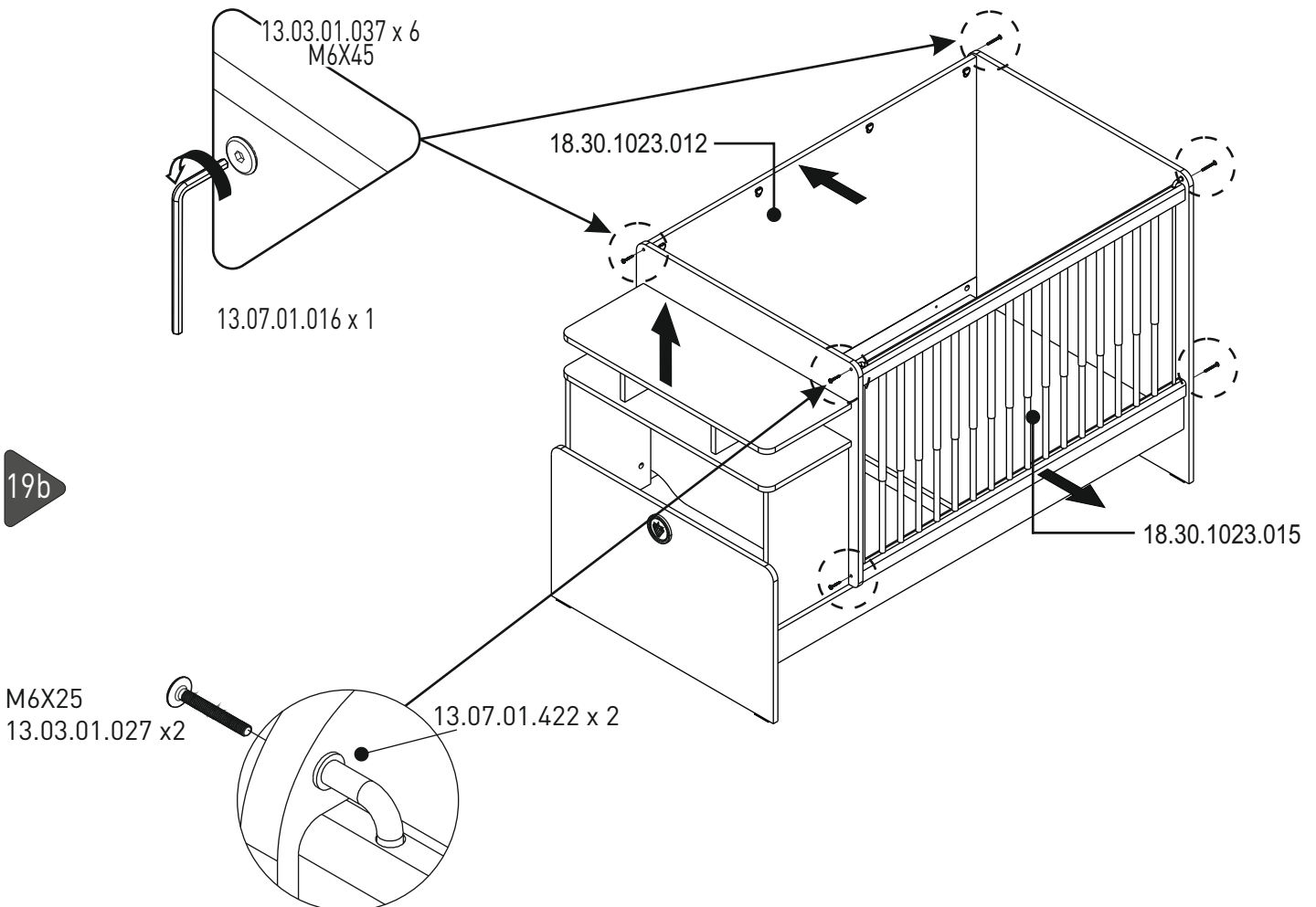
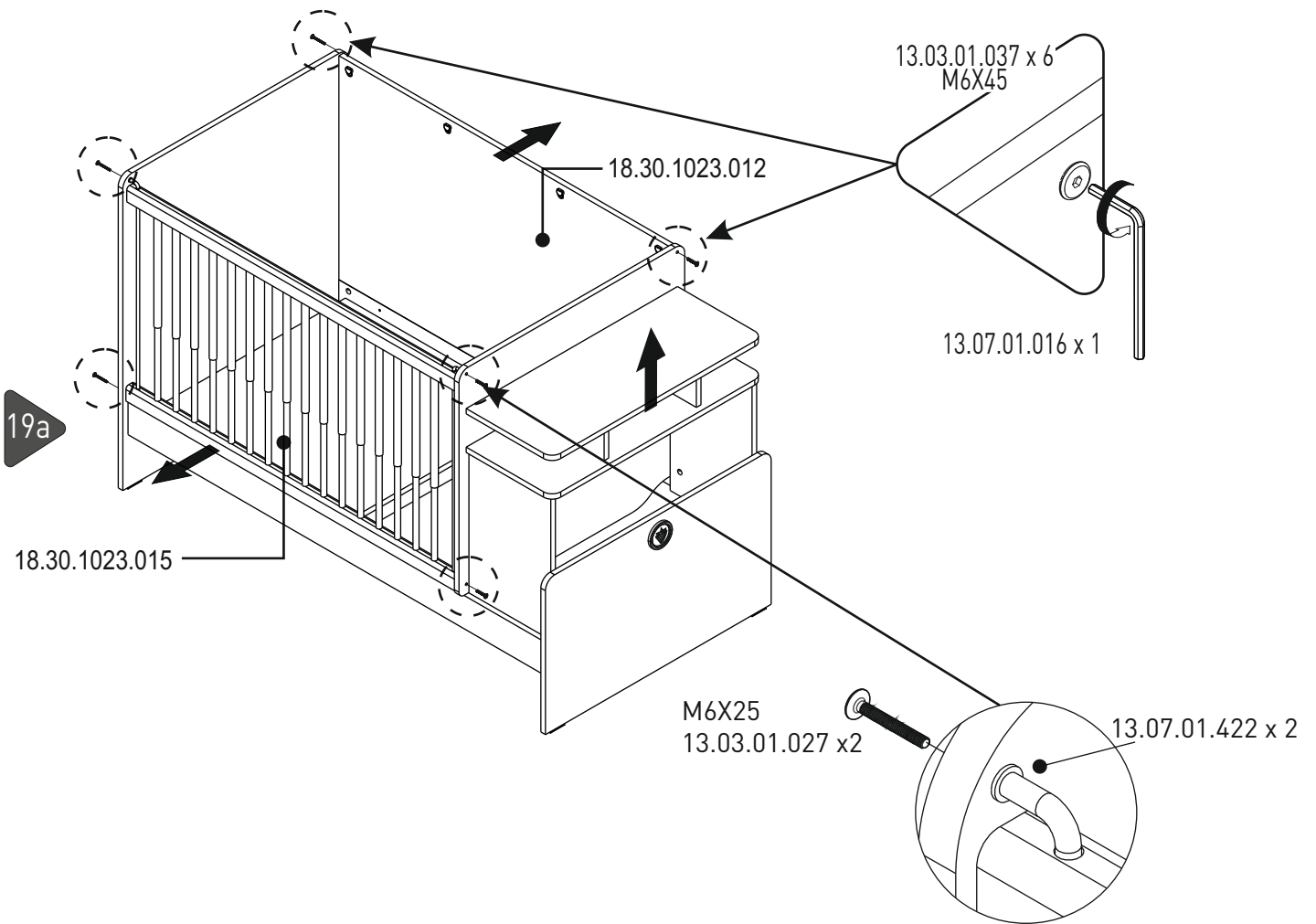

20a

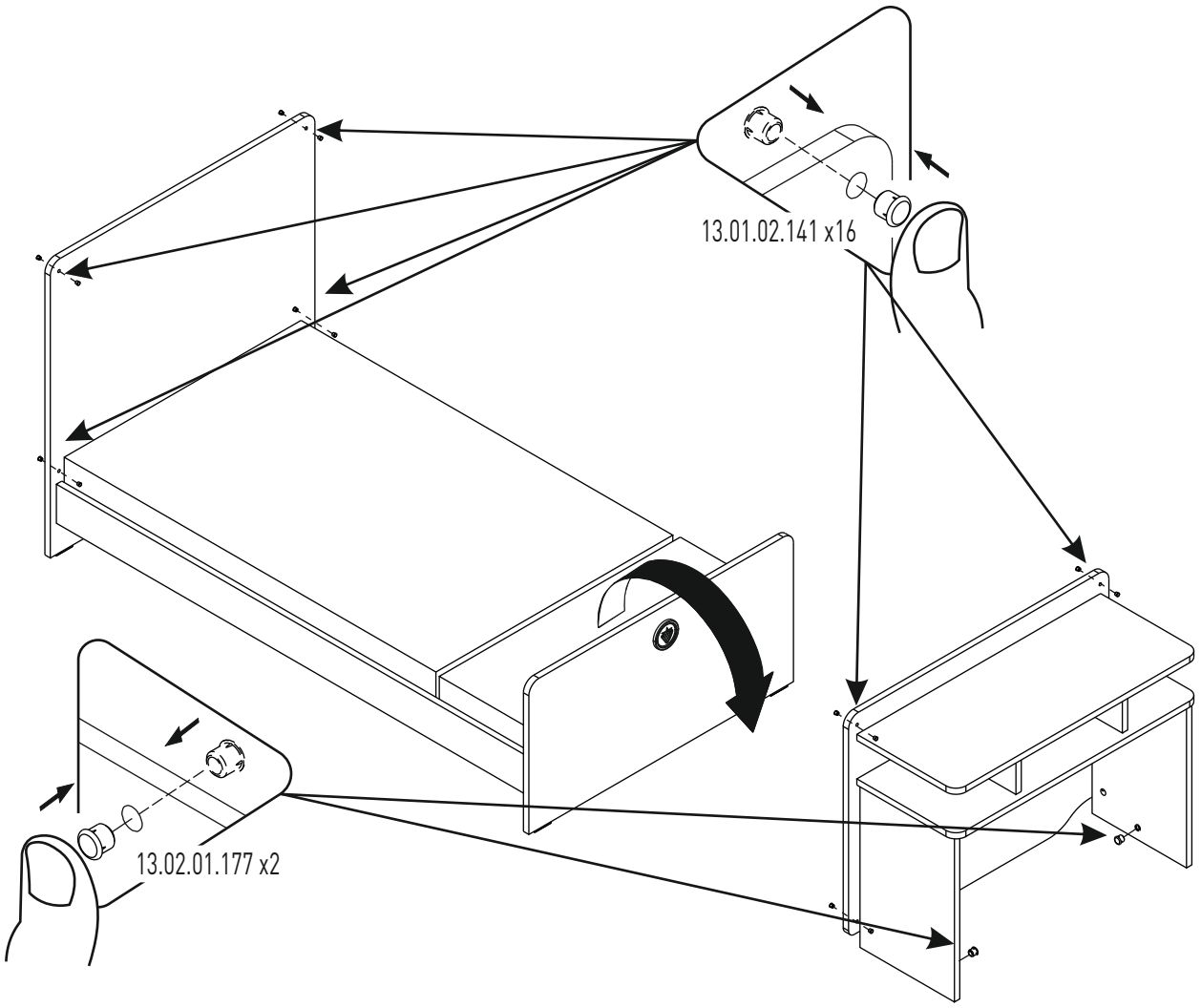

20b

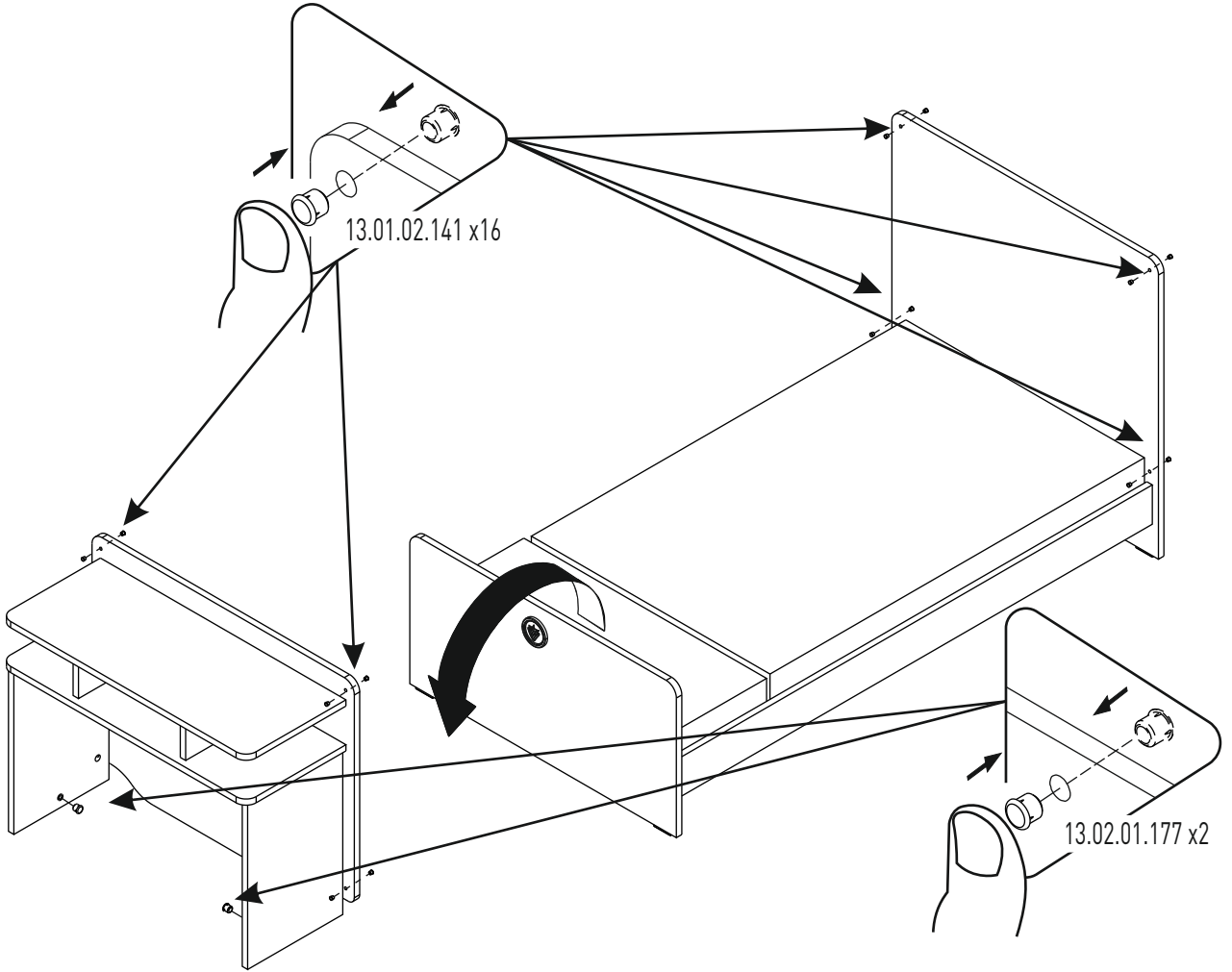

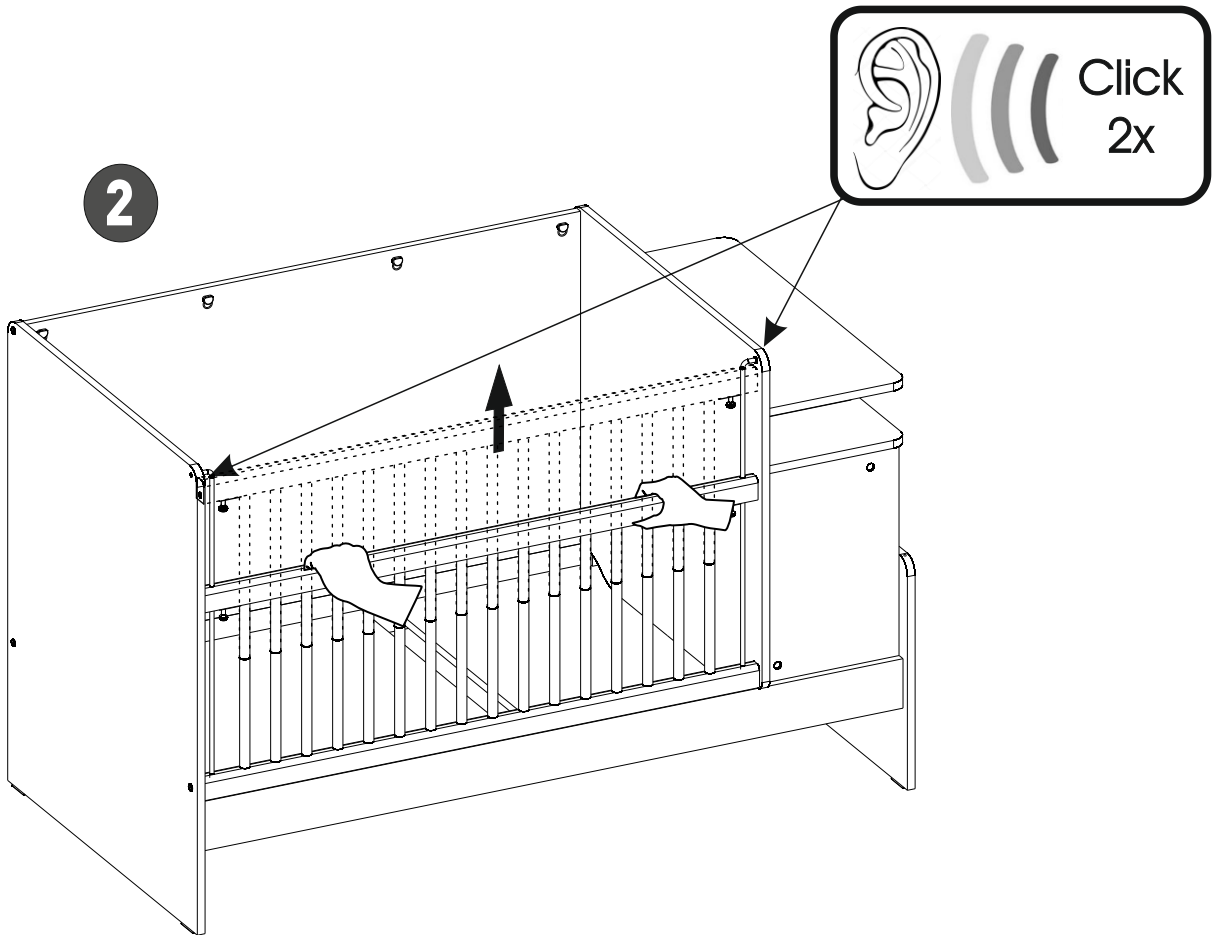
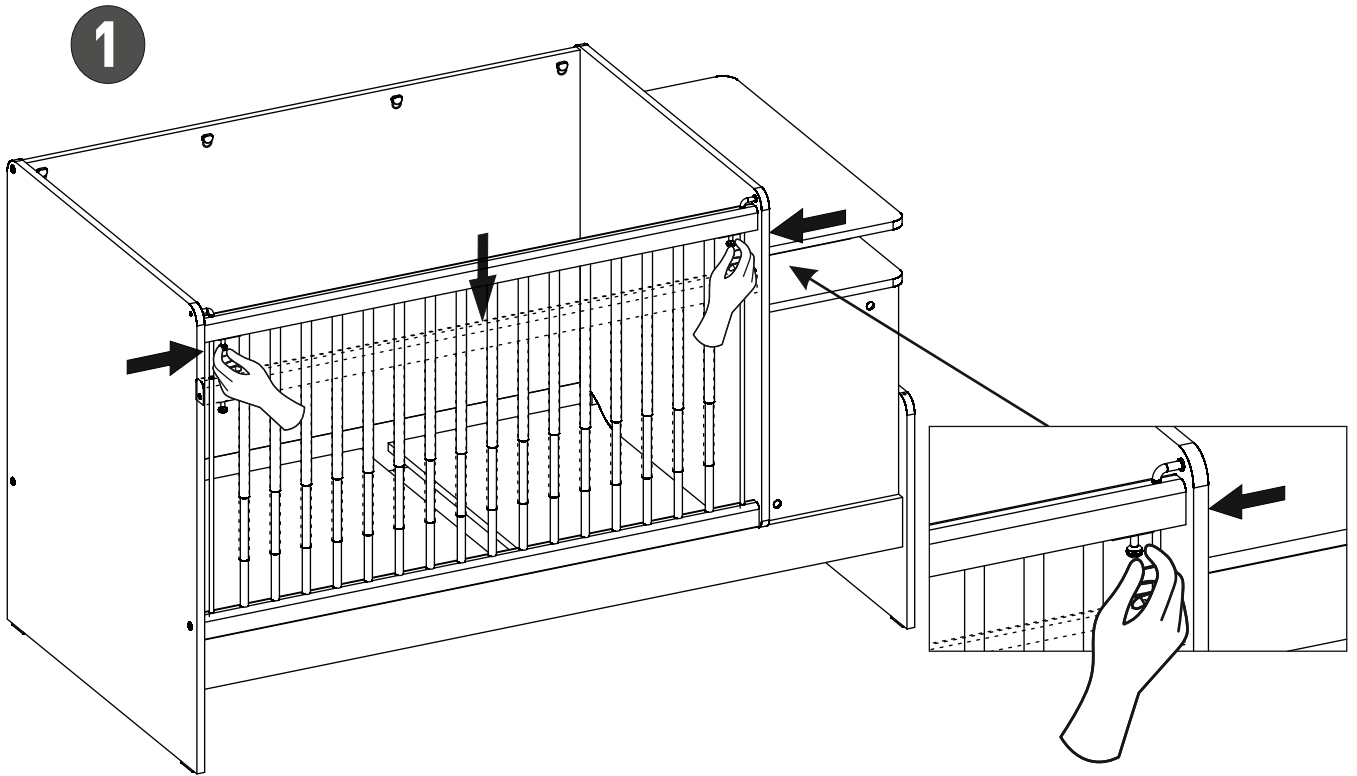

1

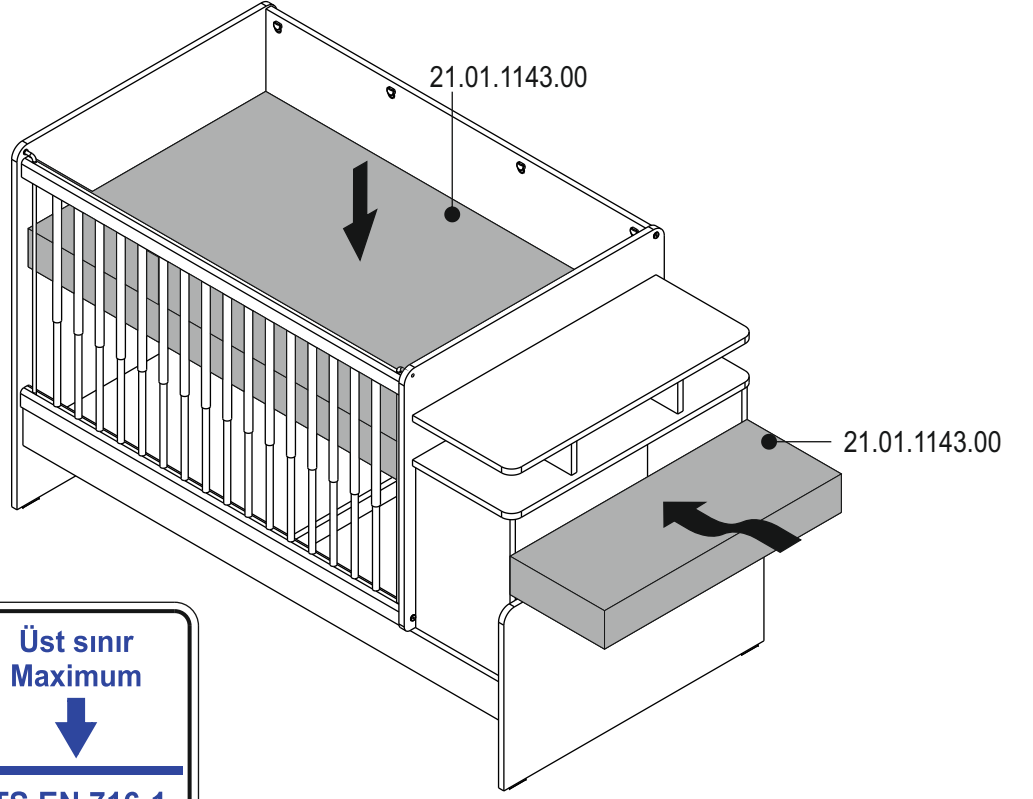

**Üst sınır
Maximum**

TS EN 716-1

⚠ UYARI / WARNING

- * Yatak toplam yüksekliğinin 10 cm'yi geçmemesine dikkat ediniz.
- * Please make sure that the total height of the mattress does not exceed 10 cm.
- * Yatak üzerine ikinci bir yatak eklemeyiniz.
- * Please do not use a second mattress on the mattress.

2

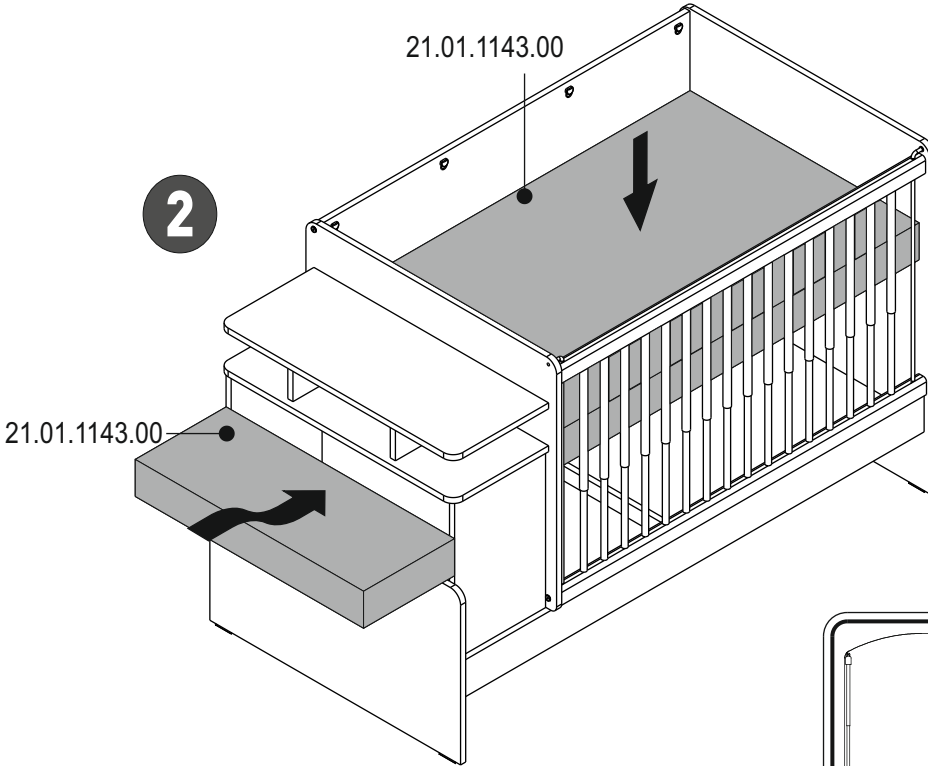

**Üst sınır
Maximum**

TS EN 716-1

⚠ UYARI / WARNING

- * Yatak toplam yüksekliğinin 10 cm'yi geçmemesine dikkat ediniz.
- * Please make sure that the total height of the mattress does not exceed 10 cm.
- * Yatak üzerine ikinci bir yatak eklemeyiniz.
- * Please do not use a second mattress on the mattress.

